

H16

Manual Flow Control Valve



Function

- Variable orifice, restrictive type, hydraulic flow control, non-pressure compensated. Pressure balanced, bi-directional flow.
- 90 degree rotation.
- Can be used with most of our standard Motorized Flow Control manifold packages

Operating Pressure

- 3000 psi maximum differential
- Consult factory for higher operating pressures

Flow Ranges

Based on 100 PSI pressure differential with valve fully open.
See pressure drop curves for additional application data

- **15** 0-15 gpm (Equivalent to Ø.25" orifice at full open)
- **20** 0-20 gpm (Equivalent to Ø.35" orifice at full open)
- **35** 0-35 gpm (Equivalent to Ø.49" orifice at full open)
- **50** 0-50 gpm (Equivalent to Ø.56" orifice at full open)
- Custom ranges are available upon request

Construction

- Cage, Body and Spool: Steel, exposed parts plated
- Motor housing assembly: Anodized aluminum
- Standard line bodies are aluminum
- Steel bodies are available upon request

Seal Material

- Buna N and polyurethane standard
- Viton optional

Internal Leakage

- 5 cubic inch per minute per 1000 psi

Temperature

- -40 to 120°C

Cavity

- C 16-2 industry common cavity

Valve Installation Torque

- 65 ft-lbs

Cartridge Weight

- H16 cartridge only 1.2 lbs
- H16 with aluminum body 4.1 lbs

Seal kit

- SFP25249

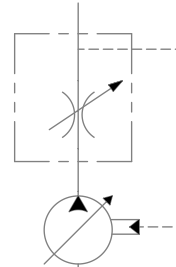

Example Schematic with 10183LS Line Body.

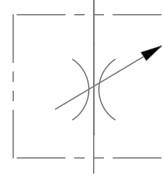

Hydraulic Symbol

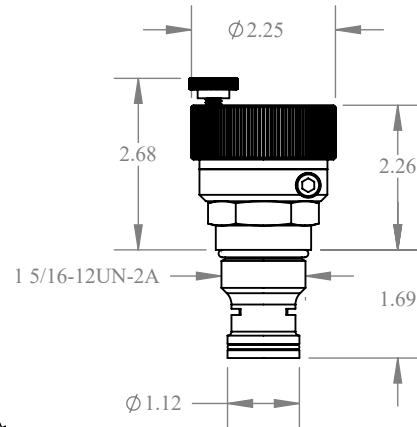

POSITION LOCK SCREW

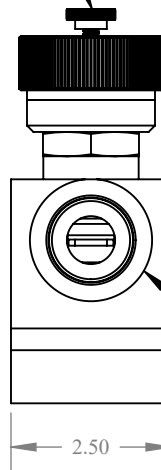

SAE -4 ORB

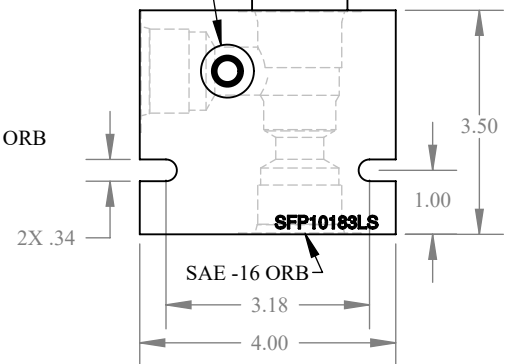

H16

Flow range:

- 15** 0-15 gpm
- 20** 0-20 gpm
- 35** 0-35 gpm
- 50** 0-50 gpm

Line bodies:

- 10183** SAE-12 ports
- 10183LS** SAE-16 ports and SAE-4 LS port